



How I treat type 2B von Willebrand disease

Rebecca Kruse-Jarres^{1,2} and Jill M. Johnsen^{1,2}

¹Washington Center for Bleeding Disorders at Bloodworks Northwest, Seattle, WA; and ²Department of Medicine, University of Washington, Seattle, WA

Type 2B von Willebrand disease (VWD) is an inherited bleeding disorder caused by changes in von Willebrand factor (VWF) that enhance binding of VWF to GPIb on platelets. Although this disorder is seemingly well defined because of this single molecular defect, in reality type 2B VWD is a clinically heterogeneous disorder that can be difficult to identify and manage. Diagnostic criteria include a history of mucocutaneous bleeding, laboratory studies showing enhanced VWF binding of platelets and/or a 2B VWD genetic variant, and a family history consistent with autosomal dominant inheritance. Thrombocytopenia, although not always present, is common and can be exacerbated by physiologic stressors such as pregnancy. The mainstay of therapy for type 2B VWD is VWF replacement therapy. Adjunct therapies useful in other types of VWD, such as antifibrinolytics, are also used in type 2B VWD. 1-Desamino-8-D-arginine vasopressin (DDAVP) is controversial because of exacerbation of thrombocytopenia, but is, in practice, sometimes used for minor bleeding. Here we review the available evidence and provide 3 clinical cases to illustrate the intricacies of diagnosing type 2B VWD to describe the response to DDAVP and to review complexities and management during pregnancy. (*Blood*. 2018;131(12):1292-1300)

Introduction

von Willebrand disease (VWD) is a common and complex disorder, with >20 distinct historical subtypes. These descriptions formed the basis for the simplified classification of VWD¹ (Table 1) by consolidating subtypes with similar features. The diagnosis of VWD is based on mucocutaneous bleeding, abnormal von Willebrand factor (VWF)-specific laboratory studies, and family history. Type 2 forms of VWD are characterized by qualitative abnormalities of VWF structure and/or function. Although type 2 VWF is functionally defective, the antigen (quantity) of VWF found in type 2 VWD patients can be normal. This can delay the diagnosis of VWD or lead to incorrect classification in the absence of more complete VWF laboratory testing.

Type 2B VWD is distinguished from other type 2 VWD types by a gain-of-function defect in VWF that causes enhanced VWF-platelet interactions via platelet GPIb. Other laboratory features, such as loss of high-molecular-weight VWF multimers and thrombocytopenia, are common in type 2B VWD, but are not universal.² The mainstay of type 2B VWD treatment is VWF replacement therapy. Adjunctive therapies common in other types of VWD are also useful in type 2B VWD, including antifibrinolytics (aminocaproic acid, tranexamic acid), topical hemostatic agents, and interventions for uterine bleeding (intrauterine devices, hormonal therapies, anatomic measures). Thrombocytopenia, a distinctive feature of type 2B VWD, is not always present at baseline; the contribution to bleeding and need for platelet transfusion poorly defined. 1-Desamino-8-D-arginine vasopressin (DDAVP) is controversial because of exacerbation of thrombocytopenia, but in practice is used by some patients for minor hemostatic challenges.

This article uses clinical cases to delineate the intricacies of diagnosing type 2B VWD, examine treatment options, and discuss management of bleeding and pregnancy in this disorder.

Diagnosis of type 2B VWD

Case 1

A 27-year-old woman presented with bleeding from an upper ear piercing. She tolerated the piercing, but several hours later started bleeding "like a spring," saturating towels. An ambulance was called when she developed dizziness and vomiting. In the emergency room, the piercing site was clamped. She reported a lifelong history of epistaxis, easy bruising, and vaginal bleeding requiring multiple transfusions but improved on oral contraceptive pills. Her physical examination was only remarkable for tachycardia and profuse bleeding each time the clamp was released. Her laboratory studies showed decreasing hemoglobin and platelet counts and unremarkable screening coagulation tests (Table 2). Three units of packed red blood cells were ordered, Hematology was consulted, and additional laboratory studies were ordered. Empirically, aminocaproic acid 1 g IV was administered and the patient maintained hemostasis after clamp release. On hospital day 1, she felt improved, her ear piercing bandage remained dry, her complete blood count was improved, and laboratory studies suggested VWD. She was discharged on oral aminocaproic acid for outpatient evaluation.

In the clinic, she reconfirmed her bleeding history and also reported that her mother had bleeding after miscarriage and a gluteal intramuscular injection site hematoma requiring surgery. Laboratory studies were obtained (Table 2), which supported the diagnosis of type 2B VWD.

Table 1. Laboratory testing for the diagnosis of type 2B VWD compared with similar disorders

	Description	Measures plasma VWF protein in circulation by ELISA	Measures VWF binding to normal or fixed platelets	Measures plasma FVIII activity	A calculation of VWF activity relative to VWF protein; low ratios suggest type 2 VWD	Measures plasma VWF binding to collagen	Identifies distribution of VWF multimers by gel electrophoresis	No. platelets per whole blood volume (usually automated)	Measures ability of patient VWF to aggregate patient's own platelets in presence of ristocetin	Detects DNA variants in genetic regions tested	Modified RIPA testing patient's VWF platelets with normal VWF	
	Laboratory test	VWF:Ag	VWF:RCo	FVIII:C	VWF:RCo/VWF:Ag ratio	VWF:CB	VWF multimer structure	Platelet count	RIPA	DNA testing	Specialized plasma RIPA ^a	Specialized platelet RIPA ^a
Bleeding disorder	Type 2B	Decreased to normal	Usually low	Decreased to normal	Usually <0.5-0.7	Decreased to normal	Largest multimers often reduced/absent	Decreased to normal	Increased to low concentrations of ristocetin	VWF A1 domain ^a	Increased to low concentrations of ristocetin	Normal
	Platelet-type VWD (pseudo-VWD)	Decreased to normal	Decreased	Decreased to normal	Can be <0.5-0.7	Decreased to normal	Largest multimers absent	Decreased to normal	Increased to low concentrations of ristocetin	GP1BA	Normal	Increased to low concentrations of ristocetin
	Type 2A	Usually low	Markedly decreased	Decreased to normal	<0.5-0.7	Decreased	Largest and intermediate multimers absent	Normal	Decreased	Multiple VWF regions ^b	NA	NA
	Type 2M	Variably decreased	Decreased	Variably decreased	Usually <0.5-0.7	Decreased to normal	Normal, occasionally ultralarge forms	Normal	Variably decreased	Multiple VWF regions ^b	NA	NA
	Type 2N	Normal	Normal	Decreased	>0.5-0.7	Normal	Normal	Normal	Normal	VWF D'D3	NA	NA

Laboratory features shared with type 2B VWD are indicated in green; dissimilar features indicated in yellow.

ELISA, enzyme-linked immunosorbent assay; NA, not available.

^aThese specialized RIPAs should be performed at the same time.

^bDNA variants in the VWF A1 domain have been described in types 2A, 2B, 2M, 1, and 3 VWD (and normal individuals), but the types of DNA variants indicative of 2B VWD are distinct.

Table 2. Laboratory diagnosis of type 2B VWD in a 27-y-old woman with life-threatening bleeding after ear piercing (case 1)

Tests	Results*	Test parameters
Coagulation		
aPTT, s	25.6	24.0-30.9
PT, s	9.5	9.5-12.7
INR	0.9	0.8-1.2
TT, s	19	16-21
Fibrinogen activity, mg/dL	199	231-411
Blood cell counts		
Hct	25.9 (L)	34%-43%
Plt	125 (L)	130-330
MPV	11.9	
VWD		
VWF:Ag	56	49%-173%
VWF:RCo	18 (L)	37%-154%
VWF:CB	20 (L)	
FVIII activity	94	52%-152%
VWF multimers	Abnormal	Missing high- and some intermediate-molecular-weight multimers
Platelet laboratory		
RIPA	85	Risto 1.5 mg/mL
	84	Risto 1.0 mg/mL
	82 (H)	Risto 0.5 mg/mL
Other platelet aggregation tests	Normal	Agonists: ADP, collagen, epinephrine, arachidonic acid, U44619 (TXA2)
Genetic		
VWF exon 28 genotype	Pathogenic variant detected	VWF c.[3922C>T]+[=], p.[Arg1308Cys]+[=]

ADP, adenosine 5'-diphosphate; aPTT, activated partial thromboplastin time; CB, collagen binding; H, high; Hct, hematocrit; INR, international normalized ratio; L, low; MPV, mean platelet volume; Plt, platelet; PT, prothrombin time; RBC, red blood cell; TT, thrombin time.

*2 d after RBC transfusion; see case 1 for presenting complete blood count.

Discussion of case 1 Patients with an inherited bleeding disorder often remain undiagnosed into adulthood. Mucocutaneous bleeding, the pattern seen in this patient and her mother, is indicative of a defect in primary hemostasis, with the most likely diagnoses being VWD,³ although an inherited platelet disorder could also be consistent with this presentation.

In approaching the diagnosis, it is important to understand the physiology of VWF. VWF normally interacts with platelets to mediate platelet aggregation and localize platelets to sites of vascular injury.⁴ Normally, circulating VWF does not interact significantly with platelets, but rather interacts with platelets once VWF becomes tethered, such as when VWF binds to an injured vessel wall. Primary VWF-platelet binding occurs between the VWF A1 domain and GPIb on platelets, and secondary binding occurs between the platelet GPIIb-IIIa complex and VWF C domain (Figure 1). In type 2B VWD, VWF-GPIb platelet binding is pathologically enhanced, resulting in abnormal complexes

between platelets and large adhesive forms of VWF. These complexes, not seen in other subtypes of VWD, are thought to account for the thrombocytopenia and depletion of large VWF multimers observed in many, but not all, cases of type 2B VWD.⁴⁻⁶ The degree of thrombocytopenia can vary and may be exacerbated at times of increased VWF production or secretion, such as during physical effort, inflammation, or pregnancy. Thrombocytopenia is rarely so severe as to be thought to contribute to clinical bleeding.^{7,8} In this patient, the mucocutaneous bleeding history, maternal bleeding, and unexplained thrombocytopenia raised clinical suspicion for type 2B VWD.

This patient's evaluation illustrates a common path to making the laboratory diagnosis of VWD. Appropriate processing of laboratory samples is critical for VWF evaluations⁹; pseudo-thrombocytopenia and other causes of thrombocytopenia should be excluded. When VWD is suspected, initial testing should include factor VIII procoagulant activity (FVIII:C); VWF antigen (VWF:Ag), a measure of platelet-dependent VWF activity; and consideration for VWF-collagen binding. VWF multimer analysis is needed to distinguish types of VWD. For type 2B VWD, ristocetin-induced platelet aggregation (RIPA) studies and/or genetic testing are needed to establish the diagnosis (Table 1).

The standard measure of VWF platelet-dependent activity is VWF ristocetin cofactor activity (VWF:RCo), which, in its conventional form, quantitates the ability of plasma VWF to agglutinate washed or formalin-fixed platelets via platelet membrane glycoprotein 1b α in the presence of ristocetin.¹⁰ Importantly, ristocetin binds to both VWF and platelets.^{11,12} In VWF:RCo, normal platelets are used; therefore, this assay should reflect variation in VWF only. The RCo assay has long been considered to be a sensitive and specific test for VWD.¹³ The assay is limited, though, by high disparity and low sensitivity^{14,15} and can be affected by benign VWF genetic variants.¹⁶ Other methods have been developed for platelet-dependent VWF activity^{14,17} and studies are ongoing to better understand VWF:RCo alternatives.

In type 2 VWD, VWF:RCo can be disproportionately decreased relative to VWF:Ag. This is usually the case in type 2A VWD and sometimes in type 2B, in large part because of the dependence of the ristocetin-mediated platelet-VWF interaction on the presence of larger VWF multimers. A ratio of VWF:RCo/VWF:Ag <0.7 is often observed in type 2 VWD. In VWD, a conservative screening ratio threshold of 0.6 has been proposed to proceed to specific testing for a qualitative (type 2) VWF defect.^{4,18} In this patient, the VWF:RCo was very low (18%) and the VWF:RCo/VWF:Ag ratio was 0.3, highly suggestive of type 2 VWD.

Analysis of plasma VWF multimers is critical for the proper diagnosis and classification of VWD.⁶ The normal multimeric distribution is an orderly ladder of major protein bands of increasing molecular weight, going from the smallest to the largest VWF multimers separated by agarose gel electrophoresis. The VWF:RCo/VWF:Ag ratio is less sensitive than multimer gel techniques in identifying qualitative VWF defects,¹⁹ supporting a continued important role for VWF multimer analysis in the evaluation of VWD. In type 2B VWD, multimer patterns can vary from pronounced absence of high-molecular-weight multimers to normal.² Our patient also had a markedly abnormal

Table 3. Laboratory monitoring of patient with type 2B VWD during pregnancy (case 3)

Gestational age, wk	aPTT (s)	Factor VIII:C (%)	VWF:RC ₀ (%)	VWF:Ag (%)	Platelet count ($\times 10^3/\text{mm}^3$)
Historical	—	53	<10	60	350
9	—	60	12	52	163
20	—	92	19	61	149
26	26.5	112	<5	77	134
31	26.6	103	5	73	163
33	27	151	21	113	82
35	—	136	17	117	31

VWF multimer pattern (Figure 1A), narrowing her VWD diagnosis to type 2A VWD, 2B VWD, or platelet-type VWD.

Distinct from VWF:RC₀, the RIPA assay measures VWF-platelet interactions by adding ristocetin directly to patient platelet-rich plasma and measuring platelet aggregation. RIPA is the primary VWF functional assay that can distinguish type 2A from 2B VWD. Hyperresponsiveness in the RIPA at low ristocetin concentrations (<0.7 mg/mL) is diagnostic of VWF-GPIb enhanced function and indicative of either type 2B VWD or, less commonly, platelet-type VWD. In this patient's case, RIPA demonstrated enhanced high activity at low-dose ristocetin (Table 2).

It is critical to distinguish type 2B VWD from platelet-type VWD either by genetic testing or specialized testing (Table 1) because platelet-type VWD is not responsive to VWF replacement therapy. Platelet-type VWD is a GPIb gain-of-function platelet defect that causes hyperfunctional platelets and phenotypically mimics VWD with mucocutaneous bleeding, loss of higher VWF multimers, enhanced RIPA, and variable thrombocytopenia.²⁰ The correct diagnosis can be established by specialized RIPA mixing tests that reconstitute separated patient blood components (plasma and platelets) with normal donor components (platelets and plasma) to determine if the gain-of-function RIPA abnormality is conferred by the patient's plasma (VWF) or platelets.²¹ Additionally, newer tests that use immobilized gain-of-function GPIb to measure VWF activity have also been reported to distinguish 2B VWD.^{22,23} However, these tests require specialty laboratories and are not widely available. Alternately, the diagnosis of type 2B VWD can be made through genetic testing.^{24,25}

Genetic testing can be diagnostic for type 2 VWD²⁵ because multiple known causative DNA variants have been reported in the VWF A1 domain (Figure 2).²⁶ VWD genotyping can also be informative as to concordance of the patient's presentation with known type 2B phenotypes because a spectrum of VWF A1 domain variants have been associated with varying degrees of abnormalities in multimers and platelet counts.² DNA sequencing of VWF exon 28 confirmed the diagnosis of type 2B VWD in this patient by identifying the pathogenic variant VWF c.3922C>T, p.Arg1308Cys.

Notably, platelet function analyzer 100 (PFA-100) closure times were not informative in this case. The PFA-100 system,

which measures platelet binding under high shear,^{27,28} is controversial in the diagnosis of VWD, and some type 2 VWD patients can have normal results.²⁹ Additionally, relevant to this case, PFA-100 closure time is confounded by anemia and thrombocytopenia.³⁰

Now that a proper diagnosis of type 2B VWD has been established in this patient, she should receive VWF factor replacement for hemostatic challenges in the future. This case also illustrates the usefulness of antifibrinolytic and hormonal therapies in improving bleeding in type 2B VWD, both of which were used with success before her diagnosis.

Thrombocytopenia and DDAVP in Type 2B VWD

Case 2

An 18-year-old woman was attending a VWD educational patient event. She listened intently and then asked how much the lecturer knows about immune thrombocytopenia (ITP). She reports being diagnosed with VWD at age 6 and ITP at age 12. She has a lifelong history of easy bruising, childhood epistaxis, and a family history of VWD. She does not know her VWD type or baseline laboratory levels. Shortly after menarche, she started having heavy menstrual bleeding lasting up to 2 to 3 weeks, saturating protection every 30 to 60 minutes on heavy days. She missed school because of heavy menstrual bleeding. She did not tolerate oral contraceptive pills because of depression or antifibrinolytics because of nausea and headaches. She was instructed to take DDAVP nasal spray on the first and second days of her menses. Although the DDAVP symptomatically helped with menstrual flow, she states she "developed ITP, which always got worse after taking desmopressin."

In type 2B VWD, DDAVP is thought to cause release of higher molecular weight and hyperfunctional VWF, provoking platelet aggregation and thrombocytopenia. This caused clinical concern for the potential to exacerbate bleeding or that circulating platelet aggregates could be harmful³¹ and resulted in the longstanding practice of avoiding the use of DDAVP in type 2B VWD. Around 30% to 38% of patients with VWD 2B are thrombocytopenic at baseline, which correlates to the absence of large VWF multimers and genotype.² Bleeding severity in 1 study correlated inversely to platelet count,³² but there was no

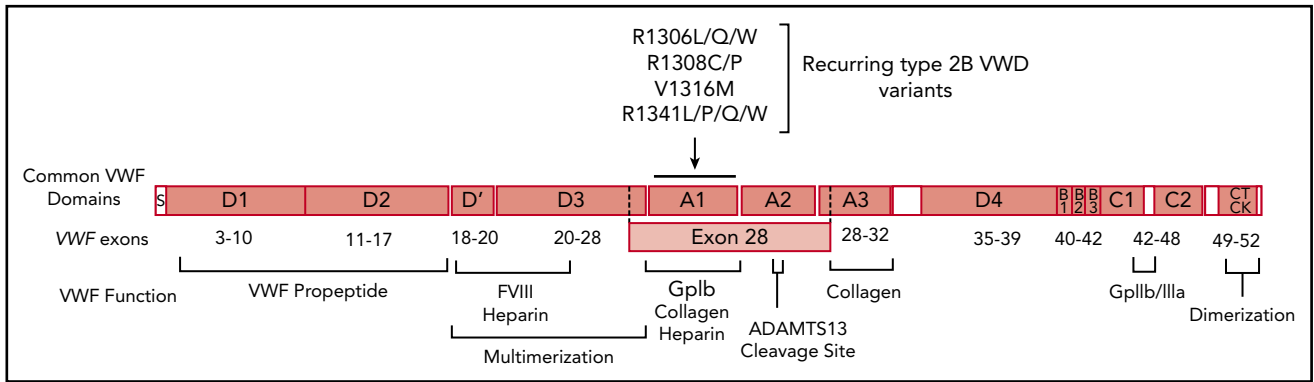

Figure 1. Common VWF A1 domain variants in type 2B VWD. Scale schematic of VWF showing the common VWF domains (gray boxes). The exons encoding each domain are numbered and the VWF regions associated with specific VWF functions are shown. In type 2B VWD, variation in the VWF A1 domain (encoded within VWF exon 28) confers enhanced binding to platelet GPIb. Amino acid residues with recurring substitutions reported in type 2B VWD²⁶ are shown.

correlation in a more recent cohort.² Stressors such as pregnancy, infection, and surgery can result in decreased platelet counts, which may partially correlate to genotype.³² A decrease in platelet count is also experienced and tolerated in patients with type 2B VWD under physiologic conditions, such as exercise.³³ DDAVP-provoked thrombocytopenia is transient, reaching its lowest count after 30 minutes, and rising again over the next 4 hours.³⁴ It has been proposed that this thrombocytopenia is not related to platelet activation and consumption, but rather to transient agglutination and release.³⁵ In type 2B VWD, the bleeding time (which is no longer recommended) is improved by DDAVP, but it usually does not correct completely and is independent of the platelet count.^{36,37} An older review of 7 patients found DDAVP can be effective and well tolerated when used prophylactically for surgery (hysterectomy, cholecystectomy, dermoid cyst removal) or dental extraction in type 2B VWD,³⁷ but data from larger cohorts are not available.

This patient does not have primary ITP.³⁸ Rather, this history of thrombocytopenia after DDAVP raised suspicion for type 2B VWD. A laboratory investigation confirmed this diagnosis. Because DDAVP was well tolerated and improved her menstrual flow, we did not withhold DDAVP as a treatment option for her menses. For more significant hemostatic challenges, VWF replacement therapy is recommended.

DDAVP is more economical than factor concentrate and can be self-administered at home intranasally. Side effects when using nasal desmopressin are common (68% in a case review of 40 patients),³⁹ the most common of which are headache, fatigue, flush, itchy eyes, and dizziness, which generally subside after 24 hours.^{40,41} Although most adverse events are mild, some require medical attention and can be serious.^{39,41} Fluid restriction is important to avoid iatrogenic hyponatremia, and tachyphylaxis occurs with repeated dosing. Some patients report nausea, possibly in association with lower sodium levels. When DDAVP is considered, a pharmacokinetic study is recommended for all types of VWD. In type 2B VWD, before considering DDAVP, we recommend a monitored study demonstrating the platelet nadir and kinetics of platelet recovery in addition to VWF responsiveness. Studies in type 2B VWD to further define DDAVP's hemostatic effectiveness and to evaluate adverse effects, including bleeding or thrombosis related to exacerbated thrombocytopenia or circulating platelet aggregates, would be beneficial.

Type 2B VWD and pregnancy

Case 3

A 23-year-old woman with type 2B VWD presented at 9 weeks' gestation requesting a plan for her pregnancy, labor, and delivery. Prepregnancy testing found an FVIII:C of 53%, VWF:RCo of <10%, VWF:Ag of 60%, and a platelet count of $350 \times 10^3/\text{mm}^3$. Her multimer analysis showed loss of higher weight VWF multimers (Figure 1B). She appeared healthy. Repeat testing in the clinic showed an FVIII:C of 60%, VWF:RCo of 12%, VWF:Ag of 52%, and a platelet count $163 \times 10^3/\text{mm}^3$.

In healthy pregnancy, VWF:Ag levels become markedly increased (~250%) by the time of delivery. VWF:RCo and FVIII:C are also elevated by ~200% and ~150%, respectively.^{42,43} Larger VWF multimers can also be lost in normal pregnancy with advancing gestation.⁴² In women with type 2B VWD, VWF:Ag and VWF:RCo tend to increase (although not to normal pregnancy levels), and thrombocytopenia, if not evident prepregnancy, often becomes apparent and progressively worsens during pregnancy.^{7,44,45}

The patient returned at 20 weeks' gestation. An ultrasound revealed complete placenta previa, for which her obstetrician recommends cesarean section (C-section) at 34 weeks' gestation. She appeared healthy and had not had bleeding symptoms. Her FVIII:C was 92%, VWF:RCo 19%, VWF:Ag 61%, and platelet count $149 \times 10^3/\text{mm}^3$ (Table 3).

For birth planning in VWD, guidance has been proposed by several groups, but there is no consensus as to monitoring, dosing, and duration of therapy.^{29,45,46} Because VWF levels can change throughout pregnancy, laboratory testing at 34 to 36 weeks' gestation is recommended to assess VWF levels closer to delivery.⁴⁶ We monitor platelet counts (and VWF, when possible) weekly thereafter.

Although VWF replacement for C-section is recommended to achieve >50% VWF:RCo, in type 2B VWD, we treat C-section as a more major surgery, aiming for a VWF:RCo closer to ~80% to 100%⁴⁶ and a platelet count $>50 \times 10^3/\text{mm}^3$. Various plasma-derived VWF/FVIII concentrates are approved for treatment of VWD (Alphanate, Humate P, Wilate). A recombinant VWF (Vonvendi) is available, but there are no data in pregnancy. A typical dose of plasma-derived pdVWF/FVIII before the first procedure is 40 to

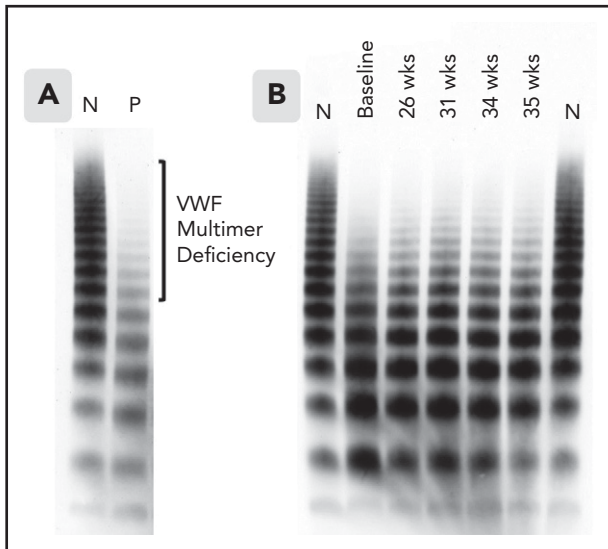

Figure 2. VWF multimer analysis of type 2B VWD cases. VWF multimer analysis (1% agarose gel) demonstrates the characteristic deficiency of high-molecular-weight multimers in 2 of the cases described with type 2B VWD. In each set of gel images, the patient plasma is compared with a normal plasma control (N). (A) The patient in case 1 (P) has loss of high- and some intermediate-weight VWF multimers. Affected multimer sizes are indicated by the bracket. (B) The patient in case 3 shows persistent deficiency of large- and some intermediate-weight VWF multimers on this VWF:Ag normalized multimer gel comparing a sample from her baseline (from an archival plasma sample) with samples during gestation (indicated in weeks [wks]).

60 IU/kg (based on VWF:RCo units). Maintenance VWF dosing should be continued at one-half of the initial bolus dose every 8 to 24 hours,²⁹ adjusting for VWF:RCo peak and trough levels and monitoring FVIII:C to avoid levels >200% to 250%.

For thrombocytopenia $<50 \times 10^3/\text{mm}^3$, we request platelet transfusion within 30 minutes of procedure, targeting a post-transfusion platelet count $>50 \times 10^3/\text{mm}^3$. For the duration, we monitor platelet counts and repeat transfusions as needed. Goals for maintenance treatment after delivery by C-section are VWF:RCo activity $>50\%$ and platelet count $>20 \times 10^3/\text{mm}^3$ for at least 5 days.⁴⁷

In our experience, anesthesiologists strongly prefer neuraxial anesthesia over general anesthesia for obstetric patients, including in type 2 VWD patients. This requires we take a thoughtful approach to VWD prophylaxis for neuraxial anesthesia. Epidural and spinal anesthesia are both common. Generally, the risk of epidural hematoma in obstetrics is very low (1 in 168 000 or less),^{48,49} but the risk of bleeding with neuraxial anesthesia in type 2B VWD is not known. Although National Heart, Lung, and Blood Institute VWD guidelines consider neuraxial anesthesia an option in VWD when VWF:RCo is >50 ,²⁹ there have been strong recommendations against neuraxial anesthesia in patients with type 2 (and specifically 2B) VWD because of a lack of evidence and because of safety concerns.^{45,46} However, there are case reports of successful epidural and spinal anesthesia in type 2B VWD,^{44,50} and occasionally women diagnosed with type 2B VWD later in life report tolerating neuraxial anesthesia before their diagnosis was known. Our approach to neuraxial anesthesia includes education of the patient on the risks and prophylaxis with both VWF replacement and correction of thrombocytopenia. Safe platelet counts and transfusion thresholds

before lumbar puncture or epidural in general have not been established, but a platelet threshold $>50 \times 10^3/\text{mm}^3$ is most commonly recommended.^{48,51} Coordination with a multidisciplinary team on delivery of VWF-containing therapies, platelet transfusion, monitoring, and minimization of trauma is essential. We recommend that if neuraxial anesthesia will be performed, it be done within 1 hour of VWF replacement therapy. If an epidural is placed, we request removal as soon as possible after delivery while drug levels are high.

At 34 weeks' gestation, ultrasound revealed resolution of the placenta previa and C-section is no longer recommended. Repeat laboratory tests find a VWF:RCo of 21% and platelet count of $82 \times 10^3/\text{mm}^3$ (Table 3). Her blood smear demonstrated some platelet clumps (Figure 3A). The patient already had VWD treatment recommendations for C-section, but now needed a birth plan for vaginal delivery.

Current recommendations for vaginal delivery target a VWF:RCo activity $>50\%$ and a platelet count $>20 \times 10^3/\text{mm}^3$.^{29,45,46} We note that this target is largely based upon treatment of non-pregnant patients and falls well below the VWF:RCo levels observed in healthy pregnancy.^{42,43} Recent studies have reported high rates of postpartum hemorrhage (PPH) in VWD despite VWF replacement, indicating that women remain at risk for excessive postpartum bleeding despite seemingly adequate treatment.⁵² Instrumentation should be avoided whenever possible to reduce the risk of trauma to the mother.⁴⁵ During the final stages of labor (or for bleeding at any time), we recommend an initial VWF replacement dose of ~ 60 IU/kg. For platelet counts $<20 \times 10^9/\text{L}$, we recommend platelet transfusion, frequent posttransfusion platelet count monitoring, and repeat transfusion as needed.⁴⁴ Platelet transfusion thresholds are poorly defined, and aggregation of transfused platelets is expected.⁴⁴ For the duration of labor and delivery, repeat VWF replacement dosing continues starting at one-half the initial bolus dose every 8 to 24 hours, adjusting using VWF:RCo peak and trough and monitoring FVIII:C to not exceed 200% to 250%.

At 35 weeks' gestation, FVIII:C was 136%, VWF:Ag 117%, VWF:RCo 17%, and platelet count $31 \times 10^3/\text{mm}^3$ (Table 3). There was more platelet clumping on peripheral blood smear (Figure 3B-C). At 38 weeks, she presents in labor. She receives VWF replacement at 60 IU/kg. She does not receive a platelet transfusion. She has an uncomplicated vaginal delivery without neuraxial anesthesia and without abnormal bleeding. She is maintained on VWF replacement at ~ 30 IU/kg every 12 hours and started on tranexamic acid 1300 mg orally 3 times daily. Three days postpartum, her platelet count is $90 \times 10^3/\text{mm}^3$; she denies heavy vaginal bleeding. She and her baby girl are doing well. Cord blood VWD testing shows FVIII:C 17%, VWF:Ag 62%, and VWF:RCo 10%, suggestive of VWD.

Prophylaxis for the postpartum period In healthy pregnancy, VWF levels peak 12 hours postpartum (mean VWF:Ag, 236 IU/dL; mean VWF:RCo, 199 IU/dL) decrease significantly by 1 week postpartum and return to baseline by 3 weeks.³² In type 2 VWD, including 2B VWD, VWF levels are much lower than normal throughout pregnancy, delivery, and the postpartum period.^{43,44} In a recent retrospective study, low VWF:RCo was associated with PPH, but, interestingly, VWF:Ag and FVIII:C were not.⁵³

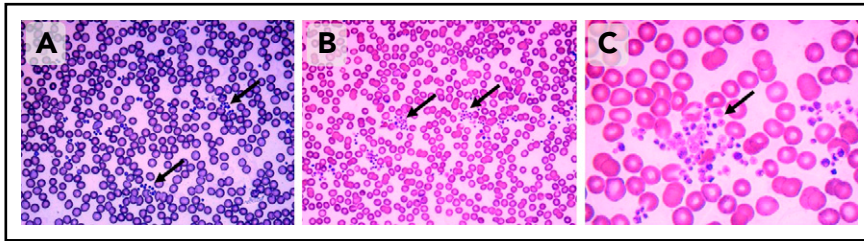

Figure 3. Peripheral blood smears showing platelet clumping in a pregnant type 2B VWD patient. Peripheral blood smears (Wright stain) of the patient in case 3, with arrows highlighting some of the platelet clumps. (A) At 33 weeks' gestation showing some platelet clumping; automated platelet count of $82 \times 10^3/\text{mm}^3$ ($\times 400$ power). (B) At 35 weeks' gestation showing worsening platelet clumping; automated platelet count $31 \times 10^3/\text{mm}^3$ ($\times 400$ power). (C) Higher magnification of platelet clumps at 35 weeks' gestation ($\times 1000$ power).

Delayed PPH is bleeding in the period between 24 hours and 6 weeks postpartum, and PPH is 15 to 20 times more common in women with VWD.^{29,54-56} VWD guidelines recommend repeat dosing of VWF factor concentrate in the postpartum period to keep VWF:RCo levels $>50\%$ for 3 to 5 days for vaginal and 5 to 7 days for C-section.^{29,46} Collectively, studies find that women with VWD bleed more postpartum than non-VWD women, despite receiving treatment.^{29,43} One study reported the average timing of presentation of PPH to be at 15.7 ± 5.2 days postpartum.⁵⁷ Tranexamic acid appears to decrease the risk of delayed PPH⁵³ and appears to be safe during lactation.⁵⁸ For type 2B VWD, we monitor closely, give VWF replacement for 3 to 7 days, consider platelet transfusion if needed, and initiate antifibrinolytic therapy for at least 2 to 6 weeks postpartum. If bleeding continues or recurs, additional treatment is used and other causes of bleeding such as uterine atony or retained products of conception should always be considered.

Four days postpartum, she denies excessive bleeding, her platelet count is $65 \times 10^3/\text{mm}^3$, and ~ 30 -minute postinfusion levels are: FVIII:C = 280%, VWF:RCo = 126%, and VWF:Ag = 369%. VWF replacement dosing is reduced to 30 IU/kg every 24 hours for another 3 days. She completes 2 weeks of tranexamic acid therapy. Four weeks after her last dose of VWF replacement, she calls complaining of heavy vaginal bleeding saturating 2 regular pads per hour. Her platelet count is $160 \times 10^3/\text{mm}^3$. She is treated with VWF replacement 60 IU/kg followed by 30 IU/kg daily for 2 days. Tranexamic acid is restarted. She achieves good control of her bleeding.

Care of the neonate Type 2B VWD is an autosomal dominant disorder, meaning each child has a 50% chance of inheriting the disorder. VWD patients and families should be counseled on the inheritance of VWD, ideally before pregnancy. Affected neonates can have platelet counts $<20 \times 10^3/\text{mm}^3$ and are thought to be at risk for bleeding and intracranial hemorrhage.⁵⁹⁻⁶¹ Low-birth-weight preterm neonates (≤ 32 weeks' gestation) may have an increased GPIIb/IIIa expression on the platelet surface and strong interactions with VWF, increasing hemorrhagic potential.⁶² There is no evidence to recommend a route of delivery; however, delivery should be achieved by the least traumatic method to the baby possible, avoiding invasive monitoring, prolonged labor, and vacuum and forceps delivery.⁴⁷

Laboratory diagnosis of the neonate is challenging, but screening may be able to be done on cord blood sampling. Infants with type 2B VWD can have thrombocytopenia and platelet clumping on peripheral smear.⁶¹ Cord blood FVIII:C and VWF:Ag may be normal, but VWF:RCo can be decreased. Normal VWF levels on cord blood do not exclude a VWD diagnosis because levels may be elevated because of stress or handling.⁶³ Genetic testing for

a familial type 2B VWD variant can also make or exclude the diagnosis.

The bleeding risk for infants is not known. Recommendations are derived from a few case reports in the literature.⁵⁹⁻⁶¹ Venipuncture and intramuscular injections should be avoided when possible. Circumcision should be considered only after consultation with the hematologist, neonatologist, and parents. Because circumcision is elective, we feel accurate diagnosis of the neonate should be established before procedures.

Vitamin K can be given orally, and heel sticks should be monitored carefully. Routine immunizations could be given subcutaneously.⁴⁷ In cases of thrombocytopenia, VWF replacement alone does not appear to raise platelet count; thus, platelet transfusion in addition to VWF replacement should be given for bleeding or invasive procedures.⁶¹ Infants with profound thrombocytopenia (platelet count <10 to $20 \times 10^3/\text{mm}^3$) should be evaluated for other causes, such as alloimmune platelet antibodies.⁶⁴

Conclusion

The diagnosis and management of type 2B VWD requires an understanding of the underlying enhanced VWF-platelet interaction. Treatment is similar to other types of VWD, but special consideration has to be given to situations that can worsen thrombocytopenia, such as pregnancy. DDAVP is controversial but may be a convenient option for some patients for minor hemostatic challenges. The mainstay of 2B VWD treatment remains VWF replacement and consideration of other VWD adjunct therapies, such as antifibrinolytics and hormonal therapies for uterine bleeding. Pregnancy planning should be formulated with a multidisciplinary team consisting of high-risk obstetrics, anesthesia, hematology, neonatology, pharmacy, blood bank, and an expert coagulation laboratory.⁴⁷

Acknowledgments

The authors first thank the patients. The authors also thank Kerry Lannert, Shelley Fletcher, Haley Huston, Shawn Prater, Colleen Engle, and Barbara Konkle for their expertise and assistance in the laboratory evaluation of these patients.

Authorship

Contribution: R.K.-J. and J.M.J. designed the concept, acquired and analyzed the data, and wrote the manuscript.

Conflict-of-interest disclosure: R.K.-J. has been a consultant for Bayer, CSL Behring, Grifols, NovoNordisk, Pfizer, Roche/Genentech, and Baxalta/Shire and is receiving research funding from Baxalta/Shire, CSL Behring, Pfizer, and Roche/Genentech. J.M.J. has been a consultant for CSL Behring and Octapharma.

Footnote

Submitted 24 June 2017; accepted 4 January 2018. Prepublished online as *Blood* First Edition paper, 29 January 2018; DOI 10.1182/blood-2017-06-742692.

REFERENCES

- Sadler JE, Budde U, Eikenboom JC, et al; Working Party on von Willebrand Disease Classification. Update on the pathophysiology and classification of von Willebrand disease: a report of the Subcommittee on von Willebrand Factor. *J Thromb Haemost*. 2006;4(10):2103-2114.
- Casonato A, Daidone V, Galletta E, Bertomoro A. Type 2B von Willebrand disease with or without large multimers: a distinction of the two sides of the disorder is long overdue. *PLoS One*. 2017;12(6):e0179566.
- Johnsen JM, Konkle BA. Differential diagnosis in the bleeding patient. In: Marder VJ, Aird WC, Bennett JS, Schulman S, White GC, eds. *Hemostasis and Thrombosis: Basic Principles and Clinical Practice*. Vol. 6. Philadelphia, PA: Wolter Kluwer; Lippincott Williams & Wilkins, Inc.; 2012.
- Johnsen JM, Ginsburg D. von Willebrand disease. In: Kaushansky K LM, Prchal JT, Levy MM, Press OW, Burns LJ, Caligiuri MA, ed. *Williams' hematology*. 9th ed. New York: McGraw Hill, Inc; 2016.
- Holmberg L, Dent JA, Schneppenheim R, Budde U, Ware J, Ruggeri ZM. von Willebrand factor mutation enhancing interaction with platelets in patients with normal multimeric structure. *J Clin Invest*. 1993;91(5):2169-2177.
- Michiels JJ, Smejkal P, Penka M, et al. Diagnostic differentiation of von willebrand disease types 1 and 2 by von Willebrand factor multimer analysis and DDAVP challenge test. *Clin Appl Thromb Hemost*. 2017;23(6):518-531.
- Rick ME, Williams SB, Sacher RA, McKeown LP. Thrombocytopenia associated with pregnancy in a patient with type IIB von Willebrand's disease. *Blood*. 1987;69(3):786-789.
- Mazurier C, Parquet-Gernez A, Goudemand J, Taillefer MF, Goudemand M. Investigation of a large kindred with type IIB von Willebrand's disease, dominant inheritance and age-dependent thrombocytopenia. *Br J Haematol*. 1988;69(4):499-505.
- Magnette A, Chatelain M, Chatelain B, Ten Cate H, Mullier F. Pre-analytical issues in the haemostasis laboratory: guidance for the clinical laboratories. *Thromb J*. 2016;14(1):49.
- Weiss HJ, Hoyer LW, Rickles FR, Varma A, Rogers J. Quantitative assay of a plasma factor deficient in von Willebrand's disease that is necessary for platelet aggregation. Relationship to factor VIII procoagulant activity and antigen content. *J Clin Invest*. 1973;52(11):2708-2716.
- Berndt MC, Du XP, Booth WJ. Ristocetin-dependent reconstitution of binding of von Willebrand factor to purified human platelet membrane glycoprotein Ib-IX complex. *Biochemistry*. 1988;27(2):633-640.
- Scott JP, Montgomery RR, Retzinger GS. Dimeric ristocetin flocculates proteins, binds to platelets, and mediates von Willebrand factor-dependent agglutination of platelets. *J Biol Chem*. 1991;266(13):8149-8155.
- Rodeghiero F, Castaman G, Tosetto A. von Willebrand factor antigen is less sensitive than ristocetin cofactor for the diagnosis of type I von Willebrand disease—results based on an epidemiological investigation. *Thromb Haemost*. 1990;64(3):349-352.
- Bodó I, Eikenboom J, Montgomery R, Patzke J, Schneppenheim R, Di Paola J; von Willebrand factor Subcommittee of the Standardization and Scientific Committee of the International Society for Thrombosis and Haemostasis. Platelet-dependent von Willebrand factor activity. Nomenclature and methodology: communication from the SSC of the ISTH. *J Thromb Haemost*. 2015;13(7):1345-1350.
- De Jong A, Eikenboom J. Developments in the diagnostic procedures for von Willebrand disease. *J Thromb Haemost*. 2016;14(3):449-460.
- Flood VH, Gill JC, Morateck PA, et al. Common VWF exon 28 polymorphisms in African Americans affecting the VWF activity assay by ristocetin cofactor. *Blood*. 2010;116(2):280-286.
- Favaloro EJ, Bonar R, Favaloro J, Koutts J. Diagnosis and management of von Willebrand disease in Australia. *Semin Thromb Hemost*. 2011;37(5):542-554.
- Ng C, Motto DG, Di Paola J. Diagnostic approach to von Willebrand disease. *Blood*. 2015;125(13):2029-2037.
- Budde U, Schneppenheim R, Eikenboom J, et al. Detailed von Willebrand factor multimer analysis in patients with von Willebrand disease in the European study, molecular and clinical markers for the diagnosis and management of type 1 von Willebrand disease (MCMMD-1VWD). *J Thromb Haemost*. 2008;6(5):762-771.
- Othman M, Kaur H, Emsley J. Platelet-type von Willebrand disease: new insights into the molecular pathophysiology of a unique platelet defect. *Semin Thromb Hemost*. 2013;39(6):663-673.
- Fronthoff JP, Favaloro EJ. Ristocetin-induced platelet aggregation (RIPA) and RIPA mixing studies. *Methods Mol Biol*. 2017;1646:473-494.
- Flood VH, Gill JC, Morateck PA, et al. Gain-of-function GPIIb ELISA assay for VWF activity in the Zimmerman Program for the Molecular and Clinical Biology of VWD. *Blood*. 2011;117(6):e67-e74.
- Roberts JC, Morateck PA, Christopherson PA, et al; Zimmerman Program Investigators. Rapid discrimination of the phenotypic variants of von Willebrand disease. *Blood*. 2016;127(20):2472-2480.
- Castaman G, Hillarp A, Goodeve A. Laboratory aspects of von Willebrand disease: test repertoire and options for activity assays and genetic analysis. *Haemophilia*. 2014;20(suppl 4):65-70.
- Goodeve A. Diagnosing von Willebrand disease: genetic analysis. *Hematology (Am Soc Hematol Educ Program)*. 2016;2016(1):678-682.
- Hampshire DJ, Goodeve AC. The International Society on Thrombosis and Haematosis von Willebrand disease database: an update. *Semin Thromb Hemost*. 2011;37(5):470-479.
- Cattaneo M, Federici AB, Lecchi A, et al. Evaluation of the PFA-100 system in the diagnosis and therapeutic monitoring of patients with von Willebrand disease. *Thromb Haemost*. 1999;82(1):35-39.
- Fressinaud E, Veyradier A, Truchaud F, et al. Screening for von Willebrand disease with a new analyzer using high shear stress: a study of 60 cases. *Blood*. 1998;91(4):1325-1331.
- Nichols WL, Hultin MB, James AH, et al. von Willebrand disease (VWD): evidence-based diagnosis and management guidelines, the National Heart, Lung, and Blood Institute (NHLBI) Expert Panel report (USA). *Haemophilia*. 2008;14(2):171-232.
- Kuiper GJAJM, Houben R, Wetzels RJH, et al. The use of regression analysis in determining reference intervals for low hematocrit and thrombocyte count in multiple electrode aggregometry and platelet function analyzer 100 testing of platelet function. *Platelets*. 2017;28(7):668-675.
- Holmberg L, Nilsson IM, Borge L, Gunnarsson M, Sjörin E. Platelet aggregation induced by 1-desamino-8-D-arginine vasopressin (DDAVP) in Type IIB von Willebrand's disease. *N Engl J Med*. 1983;309(14):816-821.
- Federici AB, Mannucci PM, Castaman G, et al. Clinical and molecular predictors of thrombocytopenia and risk of bleeding in patients with von Willebrand disease type 2B: a cohort study of 67 patients. *Blood*. 2009;113(3):526-534.
- Stakiw J, Bowman M, Hegadorn C, et al. The effect of exercise on von Willebrand factor and ADAMTS-13 in individuals with type 1 and type 2B von Willebrand disease. *J Thromb Haemost*. 2008;6(1):90-96.
- Casonato A, Gallinaro L, Cattini MG, et al. Reduced survival of type 2B von Willebrand factor, irrespective of large multimer representation or thrombocytopenia. *Haematologica*. 2010;95(8):1366-1372.
- Casonato A, Sartori MT, de Marco L, Girolami A. 1-Desamino-8-D-arginine vasopressin (DDAVP) infusion in type IIB von Willebrand's disease: shortening of bleeding time and induction of a variable pseudo-thrombocytopenia. *Thromb Haemost*. 1990;64(1):117-120.

36. Ruggeri ZM, Mannucci PM, Lombardi R, Federici AB, Zimmerman TS. Multimeric composition of factor VIII/von Willebrand factor following administration of DDAVP: implications for pathophysiology and therapy of von Willebrand's disease subtypes. *Blood*. 1982;59(6):1272-1278.
37. Castaman G, Rodeghiero F. Desmopressin and type II B von Willebrand disease. *Haemophilia*. 1996;2(2):73-77.
38. Lambert MP, Gernsheimer TB. Clinical updates in adult immune thrombocytopenia. *Blood*. 2017;129(21):2829-2835.
39. Dunn AL, Powers JR, Ribeiro MJ, Rickles FR, Abshire TC. Adverse events during use of intranasal desmopressin acetate for haemophilia A and von Willebrand disease: a case report and review of 40 patients. *Haemophilia*. 2000;6(1):11-14.
40. Stoof SC, Cnossen MH, de Maat MP, Leebeek FW, Kruip MJ. Side effects of desmopressin in patients with bleeding disorders. *Haemophilia*. 2016;22(1):39-45.
41. Leissingner C, Carcao M, Gill JC, Journeycake J, Singleton T, Valentino L. Desmopressin (DDAVP) in the management of patients with congenital bleeding disorders. *Haemophilia*. 2014;20(2):158-167.
42. Drury-Stewart DN, Lannert KW, Chung DW, et al. Complex changes in von Willebrand factor-associated parameters are acquired during uncomplicated pregnancy. *PLoS One*. 2014;9(11):e112935.
43. James AH, Konkle BA, Kouides P, et al. Postpartum von Willebrand factor levels in women with and without von Willebrand disease and implications for prophylaxis. *Haemophilia*. 2015;21(1):81-87.
44. Ranger A, Manning RA, Lyall H, Laffan MA, Millar CM. Pregnancy in type 2B VWD: a case series. *Haemophilia*. 2012;18(3):406-412.
45. Reynen E, James P. Von Willebrand disease and pregnancy: a review of evidence and expert opinion. *Semin Thromb Hemost*. 2016;42(7):717-723.
46. Laffan M, Brown SA, Collins PW, et al. The diagnosis of von Willebrand disease: a guideline from the UK Haemophilia Centre Doctors' Organization. *Haemophilia*. 2004;10(3):199-217.
47. Lee CA, Chi C, Pavord SR, et al; UK Haemophilia Centre Doctors' Organization. The obstetric and gynaecological management of women with inherited bleeding disorders—review with guidelines produced by a task-force of UK Haemophilia Centre Doctors' Organization. *Haemophilia*. 2006;12(4):301-336.
48. Estcourt LJ, Ingram C, Doree C, Trivella M, Stanworth SJ. Use of platelet transfusions prior to lumbar punctures or epidural anaesthesia for the prevention of complications in people with thrombocytopenia. *Cochrane Database Syst Rev*. 2016; (5):CD011980.
49. Ruppen W, Dery S, McQuay H, Moore RA. Incidence of epidural hematoma, infection, and neurologic injury in obstetric patients with epidural analgesia/anaesthesia. *Anesthesiology*. 2006;105(2):394-399.
50. Lagarrigue J, Richez B, Julliac B, Saltel L, Nurden P, Sztark F. Epidural labor analgesia and parturient with type 2B von Willebrand disease [in French]. *Ann Fr Anesth Reanim*. 2013;32(1):56-59.
51. Kaufman RM, Djulbegovic B, Gernsheimer T, et al; AABB. Platelet transfusion: a clinical practice guideline from the AABB. *Ann Intern Med*. 2015;162(3):205-213.
52. Stoof SC, van Steenberg HW, Zwagemaker A, et al. Primary postpartum haemorrhage in women with von Willebrand disease or carriership of haemophilia despite specialised care: a retrospective survey. *Haemophilia*. 2015;21(4):505-512.
53. Hawke L, Grabell J, Sim W, et al. Obstetric bleeding among women with inherited bleeding disorders: a retrospective study. *Haemophilia*. 2016;22(6):906-911.
54. Ramsahoye BH, Davies SV, Dasani H, Pearson JF. Obstetric management in von Willebrand's disease: a report of 24 pregnancies and a review of the literature. *Haemophilia*. 1995;1(2):140-144.
55. Shahbazi S, Moghaddam-Banaem L, Ekhtesari F, Ala FA. Impact of inherited bleeding disorders on pregnancy and postpartum hemorrhage. *Blood Coagul Fibrinolysis*. 2012;23(7):603-607.
56. Kadir RA, Lee CA, Sabin CA, Pollard D, Economides DL. Pregnancy in women with von Willebrand's disease or factor XI deficiency. *Br J Obstet Gynaecol*. 1998;105(3):314-321.
57. Roqué H, Funai E, Lockwood CJ. von Willebrand disease and pregnancy. *J Matern Fetal Med*. 2000;9(5):257-266.
58. Gilad O, Merlob P, Stahl B, Klinger G. Outcome following tranexamic acid exposure during breastfeeding. *Breastfeed Med*. 2014;9(8):407-410.
59. Burlingame J, McGaraghan A, Kilpatrick S, Hambleton J, Main E, Laros RK. Maternal and fetal outcomes in pregnancies affected by von Willebrand disease type 2. *Am J Obstet Gynecol*. 2001;184(2):229-230.
60. Mathew P, Greist A, Maahs JA, Lichtenberg EC, Shapiro AD. Type 2B vWD: the varied clinical manifestations in two kindreds. *Haemophilia*. 2003;9(1):137-144.
61. Proud L, Ritchey AK. Management of type 2b von Willebrand disease in the neonatal period. *Pediatr Blood Cancer*. 2017;64(1):103-105.
62. Cowman J, Quinn N, Geoghegan S, et al. Dynamic platelet function on von Willebrand factor is different in preterm neonates and full-term neonates: changes in neonatal platelet function. *J Thromb Haemost*. 2016;14(10):2027-2035.
63. Kulkarni AA, Osmond M, Bapir M, et al. The effect of labour on the coagulation system in the term neonate. *Haemophilia*. 2013;19(4):533-538.
64. Cremer M, Sallmon H, Kling PJ, Bühner C, Dame C. Thrombocytopenia and platelet transfusion in the neonate. *Semin Fetal Neonatal Med*. 2016;21(1):10-18.