

Bleeding risks associated with inheritance of the Quebec platelet disorder

Heather McKay, Francine Derome, M. Anwar Haq, Susan Whittaker, Emmy Arnold, Frédéric Adam, Nancy M. Heddle, Georges E. Rivard, and Catherine P. M. Hayward

Quebec platelet disorder (QPD) is an autosomal dominant bleeding disorder associated with increased urokinase-type plasminogen activator in platelets and α -granule protein degradation. To determine bleeding risks and common manifestations of QPD, a history questionnaire was developed and administered to 127 relatives in a family with QPD. Data entry was done blinded to affected and unaffected status, determined by assays for platelet urokinase-type plasminogen activator (u-PA) and fibrinogen degradation. Odds ratios (ORs), with 95% confidence

intervals (CIs), were determined for items queried. Summative bleeding scores for each individual were calculated using items with OR more than 1. Mean ages (34 years; range, 1-89 years) were similar for affected (n = 23) and unaffected (n = 104) family members. Affected individuals had higher mean bleeding scores ($P < .0001$) and a much higher likelihood (OR > 20) of having bleeding that led to lifestyle changes, bruises that spread lower or as large or larger than an orange or both, joint bleeds, bleeding longer than 24 hours after dental extractions or deep cuts, and

received or been recommended other treatments (fibrinolytic inhibitors) for bleeding. Individuals with QPD and exposure(s) to hemostatic challenges had experienced excessive bleeding only when fibrinolytic inhibitors had not been used. These data illustrate that QPD is associated with increased risks of bleeding that can be modified by fibrinolytic inhibitors. (Blood. 2004;104:159-165)

© 2004 by The American Society of Hematology

Introduction

Clinical histories are often helpful in evaluating patients that may have platelet disorders and other types of bleeding problems.^{1,2} For some inherited bleeding problems, such as von Willebrand disease, the prevalence of specific symptoms and problems has been studied in large numbers,³ but, in many rarer conditions, this information is limited and based entirely on information in case reports.⁴ Some bleeding symptoms, such as joint bleeds, are uncommon and suggest a severe disorder, whereas others (such as excessive bruising and menorrhagia) are more common and are also reported by a significant proportion of healthy individuals.^{1-3,5-9} Common clinical experiences indicate that bleeding risks are influenced by exposure to high-risk situations, the type and severity of the inherited abnormality, and administered therapy(ies). A paradigm shift has been proposed to view some inherited hemostatic abnormalities as risk factors for bleeding rather than a disease.¹⁰ Yet few studies have attempted to quantify bleeding risks,² because such estimates require retrospectively (odds ratios) or prospectively (relative risks) collected data on defined populations of patients and appropriately matched controls.

Recently, we had the opportunity to evaluate hemostatic abnormalities in an autosomal dominant bleeding disorder known as the Quebec platelet disorder (QPD).¹¹⁻¹⁶ The cases initially reported had moderate to severe delayed bleeding

problems that responded to treatment with fibrinolytic inhibitors.¹¹⁻¹³ Although these bleeding problems were initially attributed to a deficiency of functional platelet factor V, and hence the designation factor V Quebec, the disorder is now known to be associated with a complex spectrum of unique platelet and fibrinolytic abnormalities that include increased megakaryocyte expression and storage of urokinase-type plasminogen activator (u-PA), α -granule protein degradation associated with intraplatelet generation of plasmin, normal to increased plasma u-PA without increased plasma D-dimers, normal to reduced platelet counts, absent platelet aggregation responses to 6 μ M epinephrine, and normal to abnormal aggregation responses to collagen and adenosine diphosphate (ADP).¹¹⁻¹⁷

Access to affected and unaffected individuals within families with QPD, the large pedigree sizes, and definitive blood tests for QPD¹²⁻¹⁴ provided a unique opportunity to investigate bleeding risks for an autosomal dominant trait and to gather data on responses of QPD bleeding to fibrinolytic inhibitor therapy. With use of a standardized medical history questionnaire (completed by affected and unaffected blood relatives) and blood tests to independently assign affected or unaffected status, odds ratios and 95% confidence intervals were calculated for a spectrum of bleeding symptoms. We provide evidence that inheriting QPD is associated

From the Department of Pathology and Molecular Medicine and the Department of Medicine, McMaster University, Hamilton, ON, Canada; and the Department of Hematology and Oncology, Hôpital Sainte Justine, Montreal, QC, Canada.

Submitted December 1, 2003; accepted March 5, 2004. Prepublished online as *Blood* First Edition Paper, March 16, 2004; DOI 10.1182/blood-2003-11-4077.

Supported by grants from the Heart and Stroke Foundation of Ontario (NA 4379, C.P.M.H.), Bayer Canada (G.E.R.), and Aventis-Behring Canada (N.M.H. and C.P.M.H.). C.P.M.H. is supported by a Career Investigator Award from the Heart and Stroke Foundation of Ontario and a Canada Research Chair in Molecular Hemostasis from the Government of Canada. Support from the

McMaster Transfusion Research Program (funded in part by Canadian Blood Services and a Canada Research Chair) is also acknowledged.

H.M., F.D., and M.A.H. contributed equally to this work.

An Inside *Blood* analysis of this article appears in the front of this issue.

Reprints: Catherine P.M. Hayward, Rm 2N31, McMaster University Medical Center, 1200 Main St West, Hamilton, Ontario, Canada, L8N 3Z5; e-mail: haywrdc@mcmaster.ca.

The publication costs of this article were defrayed in part by page charge payment. Therefore, and solely to indicate this fact, this article is hereby marked "advertisement" in accordance with 18 U.S.C. section 1734.

© 2004 by The American Society of Hematology

with an increased risk of bleeding that often necessitates treatment with fibrinolytic inhibitors.

Patients, materials, and methods

This study was done in accordance with the recently revised Helsinki protocol for research on human subjects and with institutional ethics review board approval from Hamilton Health Sciences, McMaster University and Hôpital St. Justine. All study participants provided informed consent, and for individuals younger than 18 years of age, parental consent was obtained.

Bleeding history questionnaire

A detailed questionnaire, designed for evaluating diverse types of bleeding disorders, was developed that used interviews and focus groups with physicians and patients (purposefully selected to represent experiences with a broad spectrum of bleeding disorders) to identify important items for inclusion. For the current study, an abbreviated questionnaire was created specifically for QPD being assessed in this study, and it included 46 questions with closed-ended, “yes/no/don’t know/not applicable” choices; 7 questions with select appropriate choice(s) from a list of descriptions; and 21 open-ended questions whereby subjects could comment on the details of their bruises, bleeding problems, treatments, lifestyle changes related to bleeding, hospitalizations, surgeries, dental work, traumas, wound healing, and the bleeding histories of relatives. Sex-specific questions were used to collect information on reproductive health, bleeding problems affecting sexuality, menstrual cycles, symptoms of menorrhagia (abundant or long menses, soiling accidents, use of double protection with menses, how often sanitary products were changed during heaviest days of menses, and hysterectomies for bleeding), numbers of total and successful pregnancies, bleeding with childbirth, bleeding with circumcision, and to determine whether genitourinary bleeding symptoms included blood in semen. Participants were also invited to make comments on other issues that they felt were relevant to their medical histories. They were also questioned about heart disease, heart attacks, angina, strokes, deep venous thrombosis, and pulmonary embolism because animals with QPD-like abnormalities and increased u-PA in platelets are resistant to arterial thrombosis and more rapidly resolve pulmonary emboli.¹⁸

Questionnaires were administered to members of the families with QPD, with participation of direct descendants of affected and unaffected individuals. Histories for very young subjects were obtained from their parent(s). For consistency, all information was collected and reviewed by a single nurse with specialized experience in bleeding disorders who clarified answers and comments prior to forwarding the questionnaires for data entry. Medical histories and blood samples were analyzed independently, after assigning anonymous, coded identities to ensure privacy of collected information.

Assembly of the family tree

An updated family tree was assembled with use of Cyrillic 3 software (Cherwell Scientific, Reading, United Kingdom) by using information provided by the study participants to clarify genealogy. Affected or unaffected status of study participants was based on platelet glycoprotein analyses, and for other individuals in the pedigree their presumed affected or unaffected status was assigned on the basis of historical data provided by other family members, evidence that they had or had not transmitted QPD to offspring, and QPD blood test results (if available) from previous studies.¹²⁻¹⁶

Glycoprotein analyses

Blood samples were collected to determine which participants had the inherited platelet protein abnormalities that were previously established to be characteristic features of QPD.¹²⁻¹⁴ Briefly, whole blood samples (50 mL for adults and 30 mL for pediatric subjects; collected by Vacutainer into EDTA [ethylenediaminetetraacetic acid] anticoagulant) were transported and centrifuged, within 72 hours of collection, to isolate the platelet-rich

plasma.¹³ Platelets were then separated by centrifugation and lysed (without washing)¹³ in buffer containing broad spectrum protease inhibitors and 1% Triton X-100, as described.¹⁴ Platelet lysates were analyzed, using Western blotting procedures previously published¹⁴ and a u-PA antigen assay (DakoCytomation, Carpinteria, CA) to determine whether they contained increased platelet u-PA and α -granule fibrinogen degradation products characteristic of QPD. For 10 individuals, sample volumes were limited, and u-PA antigen levels¹⁴ were used to determine affected or unaffected status. Negative and positive controls for all protein analyses included samples from healthy controls and from individuals previously determined to have QPD.¹²⁻¹⁶ Two affected individuals, whose status was determined by Western blot assays, had insufficient lysate for u-PA antigen determination. Platelet count data were available for 21 of 23 affected family members.

Statistical analyses

Medical history data entries were double checked for accuracy, and information on affected or unaffected status was kept blinded until medical history data entry was complete. For calculation of proportions responding yes to a categorical question, the “don’t know” and “not applicable” responses were excluded. To identify symptoms associated with inheritance of QPD, odds ratio (OR) estimates with 95% confidence intervals (CIs) were determined by using the program OR 2 \times 2XK (kindly provided by Dr J. A. Julian, McMaster University) to perform cross-tabulations. Any OR estimated to be infinite was indicated as ∞ . ORs for heart disease, angina, stroke, and thromboses were calculated to determine whether these problems were less common among unaffected individuals.

Summative bleeding symptom scores for each subject (based on numbers of yes responses to items with an OR, and lower limit 95% CI, > 1) were calculated with exclusion of data for the question about relatives with bleeding. A 1-tailed Student *t* test was used to determine whether bleeding scores were higher among affected family members and to determine whether mean platelet counts were lower or platelet u-PA levels higher among affected individuals who experienced bleeding symptoms with OR more than 1. Correlation coefficients (adjusted R^2 values) were used to evaluate whether bleeding scores for affected family members correlated with reduced platelet counts or higher platelet u-PA levels.

Results

One hundred twenty-seven relatives within 2 families with known inheritance of QPD^{11,12} participated in the study. When information for the updated pedigree was acquired, a common ancestor was identified, allowing the 2 pedigrees to be merged (Figure 1). In total, 23 participants (16 men, 7 women) had increased platelet u-PA and degraded α -granule fibrinogen characteristic of QPD,¹²⁻¹⁴ whereas the other 104 participants (36 men, 68 women) had normal platelet protein profiles and were categorized as unaffected. The pattern of QPD inheritance was consistent with an autosomal dominant trait (Figure 1). Ages (mean \pm SD in years [range]) were similar for affected (36 ± 18 [3-69]) and unaffected (34 ± 18 [1-89]) participants ($P = .55$), and the oldest participant was in the third generation of the family (Figure 1). All affected and 24% of unaffected individuals indicated that they had a blood relative with a bleeding problem (Table 1).

Only affected individuals reported bleeding problems that had led to lifestyle changes, which were reduced exposures to traumatic activities such as sports (Table 1). Significant differences (OR > 1 , and a lower limit 95% CI > 1) were noted in the proportions of affected and unaffected family members reporting some bleeding symptoms (Table 1). Inheritance of QPD was associated with higher risks of experiencing abundant bruising and bleeding symptoms, as well as bruising disproportionate to trauma, although these symptoms were also reported by a considerable proportion of

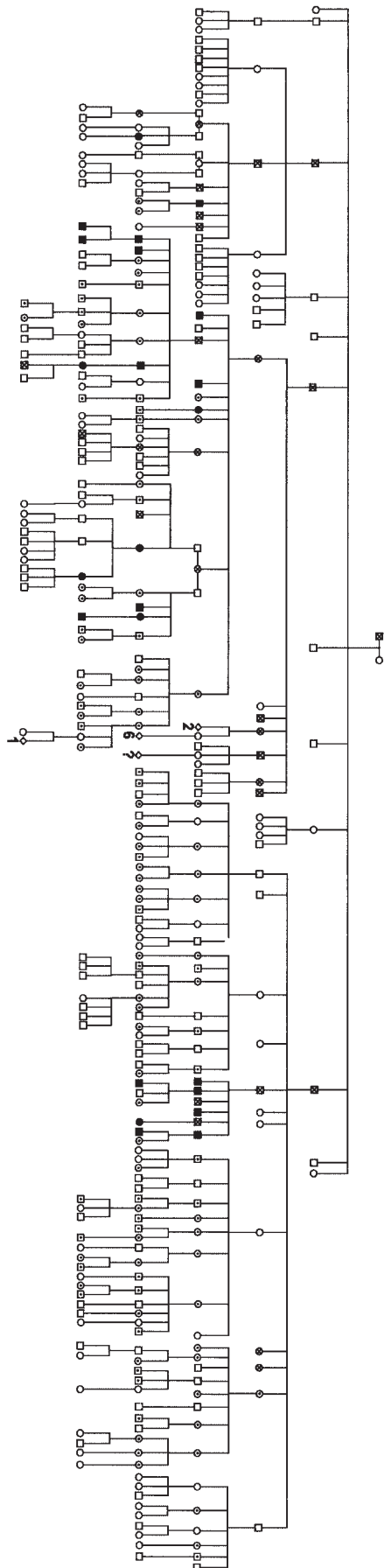

unaffected family members (Table 1). Very large bruises and bruises that tracked downward were reported exclusively by affected individuals (Table 1).

Nosebleeds were about twice as common among affected family members (Table 1). However, severe nosebleeds requiring therapy or hospitalization were uncommon, with no differences in the proportions of affected and unaffected individuals with nosebleeds longer than 15 minutes (Table 1).

Significantly more affected family members had experienced hematuria (Table 1), and none commented on the reason. In contrast, all unaffected individuals reporting hematuria qualified that it had occurred with an infection (83%) or passage of a kidney stone (17%). Joint bleeds were reported commonly (45%) and exclusively by individuals with QPD (Table 1), and affected joints included knees, ankles, shoulders, elbows, fingers, thumbs, and wrists.

Many family members and similar proportions with and without QPD had undergone dental extraction(s), but more individuals with QPD experienced abnormal bleeding or bleeding more than 24 hours after the procedure(s) (Table 1). One individual with QPD had hemorrhaged with spontaneous loss of primary teeth, requiring many interventions and treatment with tranexamic acid.

Proportionately more individuals with QPD experienced surgically related bleeding problems, and proportionately more received transfusions or other therapies for bleeding with surgery (Table 1). Many study participants had been in a serious accident (Table 1), and the described traumas were predominantly car and snowmobile accidents, serious falls, large lacerations, or blunt traumas. Proportionately more individuals with QPD bled excessively or were hospitalized after a serious accident (Table 1). Only affected individuals reported wound infections or bleeding starting 12 hours after a serious accident, but these differences were not significant (Table 1). One individual with QPD developed a cerebral hemorrhage after a fall. A higher proportion of family members with QPD reported wound healing problems after injury(ies) (Table 1). Four of the 6 individuals with QPD who reported these problems described delays in wound healing. A higher proportion of family members with QPD had been transfused, and proportionately more had received or been recommended other treatments for bleeding, namely the fibrinolytic inhibitors tranexamic acid or aminocaproic acid (Table 1). One unaffected individual received fibrinolytic inhibitors for surgery only because of his or her family history.

Among the 10 individuals with QPD who did not report abundant bleeding or bruising problems, abnormal bleeding with hemostatic challenges was common (80%), 60% had received blood transfusions, and some had experienced spontaneous hematuria (30%) and joint bleeds (20%).

When comments and categorical data on surgeries, dental extractions, and serious accidents were evaluated together, 91% (21 of 23) of individuals with QPD were identified with exposure(s) to these hemostatic challenges. With few exceptions (a hemorrhage with loss of primary teeth, joint bleeds, and hematuria), serious

Figure 1. Pedigree of the QPD family. Men (squares) and women (circles) in 7 generations are shown. Solid symbols indicate affected participants (n = 23). Symbols containing an X indicate additional individuals known or presumed to have QPD on the basis of results of previous testing (n = 6), a history of typical QPD bleeding problems, or documented QPD transmission to offspring. Open symbols containing dots indicate unaffected individuals who participated in the study (n = 104). Open symbols without dots indicate other known or presumed unaffected family members. Partners are shown for women who had children with several individuals. Children of unknown sex are shown as diamonds (representing known or unknown numbers of individuals, as indicated).

Table 1. Bleeding symptoms in members of the family with QPD

Symptom	% (proportion) responding with the symptom		OR	95% CI	Score
	A	U			
Blood relatives with bleeding problems	100 (23/23)	24 (24/98)	137	13-1000	Excluded
Had bleeding problems that led to a change in lifestyle	60 (12/20)	0 (0/9)	α	1.9- α	1
Abundant bruises or bleeding	57 (13/23)	26 (27/104)	3.7	1.3-11	1
Bruising					
Without reason	55 (12/22)	34 (34/99)	2.0	0.8-6.5	—
Disproportionate to trauma	39 (9/23)	12 (12/100)	4.7	1.5-15	1
Noticed by other people	4 (1/23)	1 (1/99)	4.5	0.1-170	—
Painful	22 (5/23)	6 (6/99)	4.3	1.0-18	—
That lasts a long time	22 (5/23)	10 (10/99)	2.5	0.6-9.2	—
That spreads toward feet or size of an orange or larger	32 (7/23)	0 (0/99)	α	4.6- α	1
Experienced deep cut(s)	70 (16/23)	59 (61/104)	1.6	0.6-4.8	—
Bleeding with this cut continued for days	56 (9/16)	3 (2/60)	37	5.6-320	1
Get nosebleeds	57 (13/23)	24 (25/103)	4.0	1.4-12	1
Have had nosebleeds					
Lasting longer than 15 min	77 (10/13)	56 (14/25)	2.6	0.5-16	—
That required nasal packing	15 (2/13)	12 (3/25)	1.3	0.1-12	—
That required cautery	24 (3/13)	24 (6/25)	1.0	0.2-6.6	—
That required transfusion	8 (1/13)	0 (0/25)	α	0.03- α	—
That required hospitalization	17 (2/12)	0 (0/25)	α	0.3- α	—
Hematuria	50 (11/22)	12 (12/104)	7.7	2.4-25	1
Joint bleeds	43 (10/23)	0 (0/104)	α	7.4- α	1
Had dental extractions	74 (17/23)	74 (77/104)	1.0	0.3-3.1	—
With abnormal bleeding	94 (16/17)	35 (26/75)	30	3.8-644	1
Bleeding for more than 24 h afterward	94 (16/17)	8 (6/72)	176	18-4250	1
Gum problems	14 (3/21)	12 (13/104)	1.2	0.2-5.1	—
Bleeding problems with surgery(ies)	50 (9/18)	9 (7/79)	10	2.7-41	1
That required transfusions	38 (5/13)	3 (2/70)	21	2.9-195	*
That required other treatments for bleeding	38 (5/13)	3 (2/71)	22	2.9-198	1
Had a serious accident	65 (15/23)	38 (39/104)	3.1	1.0-9.0	—
Bled excessively afterward	86 (12/14)	39 (15/38)	9.2	1.6-70	1
Bleeding right away	79 (11/14)	57 (17/30)	2.8	0.5-16	—
Bleeding started 12 h later	8 (1/12)	0 (0/30)	α	0.04- α	—
Needed to be hospitalized	67 (10/15)	26 (10/39)	5.8	1.4-26	1
Became anemic after accident	15 (2/13)	7 (2/30)	3.0	0.2-30	—
Needed transfusion after accident	31 (4/13)	7 (2/30)	6.0	0.8-60	—
Developed wound infection	8 (1/13)	0 (0/30)	α	0.03- α	—
Problems healing after an injury	26 (6/23)	7 (7/104)	4.9	1.3-19	1
History of transfusions	52 (12/23)	10 (10/100)	9.8	3.1-32	1*
Other treatments recommended for bleeding	87 (20/23)	2 (2/90)	293	38-3370	1

Odds ratios (ORs) and 95% confidence intervals (CIs) compare affected (A) and unaffected (U) family members.

— indicates items not included in bleeding scores; α , OR estimated as infinite.

*Overlapping queries, scored once as indicated.

Table 2. Sex-specific bleeding symptoms in the family with QPD

Symptom	% (proportion) responding with the symptom		OR	95% CI	Score
	A	U			
Men					
Circumcised	25 (4/16)	28 (10/36)	0.9	0.2-3.9	—
Abnormal bleeding when circumcised	33 (1/3)	0 (0/8)	α	0.03- α	—
Women					
Abundant menstrual bleeding	50 (3/6)	53 (33/62)	1.0	0.1-6.0	—
Menses lasting longer than 7 d	50 (3/6)	7 (4/61)	14	1.6-147	1
Blood-soiled garments with menses	50 (3/6)	45 (28/62)	1.0	0.2-8.3	—
Double protection used with menses	50 (3/6)	18 (11/61)	5.0	0.6-34	—
Hysterectomy to control menses	17 (1/6)	5 (3/63)	4.0	0.1-63	—
Been pregnant	71 (5/7)	60 (38/63)	2.0	0.2-13	—
Transfused when gave birth	40 (2/5)	5 (2/39)	12	0.8-225	—
All subjects					
Mother had/has abundant menstrual bleeding	50 (7/14)	32 (20/63)	2.0	0.6-8.1	—
Sister(s) had/has abundant menstrual bleeding	57 (4/7)	51 (22/43)	1.0	0.2-8.4	—

OR and 95% CI compare affected (A) to unaffected (U) family members. — indicates items not included in bleeding scores.

bleeding episodes in affected family members had occurred in association with hemostatic challenges. The 19 individuals with QPD who bled excessively with challenge(s) indicated this had occurred whenever fibrinolytic inhibitors had not been used. All 12 individuals with QPD who had received fibrinolytic inhibitor therapy for some ($n = 10$) or all ($n = 2$) hemostatic challenges indicated no serious bleeding occurred whenever this therapy was used. Four individuals with QPD who underwent surgery(ies) while taking fibrinolytic inhibitors (procedures included limb amputation, cholecystectomy, hysterectomy, inguinal hernia repair, removal of cysts, vasectomy) confirmed no serious bleeding had occurred, although one individual commented that a large bruise had appeared on her back after cholecystectomy. One individual with QPD hemorrhaged after a circumcision until treated with a fibrinolytic inhibitor. Three individuals with QPD who had undergone dental extractions without taking fibrinolytic inhibitors commented that their excessive bleeding had been delayed, starting sometime during the night after the procedure.

Among sex-specific items evaluated (Table 2), significant differences were found only in the proportions of affected and unaffected women with menses longer than 7 days. Only one affected man reported blood in his semen, and no individuals reported sexuality problems related to bleeding. Five affected and 38 unaffected female participants had been pregnant, and in total 9 of 9 and 87 of 102 of their respective pregnancies had been successful, with no significant differences in the mean number of successful pregnancies per individual (mean \pm SD [range]; affected, 1.8 ± 1.1 [1-3]; unaffected, 2.3 ± 1.7 [1-9]; $P = .5$). None of the affected women reported bleeding that required fibrinolytic inhibitor therapy during pregnancy, although a few were given this therapy as prophylaxis during childbirth, and one was treated after a Caesarian section. Family members indicated that an ancestor with QPD (in the third generation of the family) had given birth to 8 children at home without problems or unusual bleeding. The family pedigree data (Figure 1) indicated that fairly similar numbers of offspring had been born to affected and unaffected mothers and to affected and unaffected fathers (respective means, 3.6, 2.8, 4.9, and 2.2). For affected parents in the pedigree (Figure 1), the overall ratio of affected-to-unaffected offspring was 1:1.5, which was not significantly different from the expected 1:1 ratio (chi-square, 2.33; $P = .13$).

Five percent of unaffected and none of the affected family members had a history of heart problems, heart attacks, or angina; however, this difference was not significant (Table 3). ORs for strokes and for deep venous thrombosis and pulmonary embolism were also not significant (Table 3), but the power of the study to detect differences was limited by the low numbers of events. A hemorrhagic stroke was documented to have occurred in the QPD family member who had a prior history of stroke (Table 3) and symptomatic peripheral vascular disease (bilateral iliac artery insufficiency). The individual with QPD who had a pulmonary embolism (Table 3) indicated that it occurred after a caesarian section for preeclampsia, while she was taking a fibrinolytic

inhibitor to treat a postoperative hematoma. Her thrombotic episode was treated with intravenous heparin followed by 3 months of oral anticoagulant therapy.

Summative bleeding scores (based on numbers of yes responses for items in Tables 1 and 2 with an OR > 1 and a lower limit 95% CI > 1) were used to compare how many bleeding symptoms had been experienced by affected and unaffected individuals. Although bleeding scores (maximum, 18) were significantly lower for the group of unaffected family members (mean \pm SD [range]; unaffected, 1.6 ± 1.9 [0-10]; affected, 8.0 ± 3.9 [0-14]; $P < .0001$), there was overlap, and the 2 youngest children with QPD (ages 3 and 6 years) had scores less than 2. Among affected family members, platelet counts ranged from 120 to 245×10^9 platelets/L (mean \pm SD; $167 \pm 32 \times 10^9$ platelets/L; $n = 21$), and all had increased platelet u-PA (mean \pm SD; 275 ± 127 ng u-PA/ 10^9 platelets; range, 142-575 ng u-PA/ 10^9 platelets; $n = 21$; reference interval for unaffected,¹⁴ ≤ 1.3 ng/ 10^9 platelets), as previously reported.¹²⁻¹⁴ QPD bleeding scores did not show significant correlation with reduced platelet counts (adjusted R^2 , 0.05) or platelet u-PA levels (adjusted R^2 , 0.05). However, the individuals with QPD and hematuria had higher platelet stores of u-PA (mean \pm SD; with hematuria, 355 ± 141 ng/ 10^9 platelets, $n = 10$; without, 207 ± 51 ng/ 10^9 platelets, $n = 10$; $P = .005$) and those with wound healing problems had lower platelet counts (mean \pm SD, with healing problems, $144 \pm 27 \times 10^9$ platelets/L, $n = 6$; without, $174 \pm 31 \times 10^9$ platelets/L, $n = 15$; $P = .02$). No significant differences were identified in mean platelet counts or mean platelet u-PA levels among individuals with QPD who had other bleeding symptoms with an OR more than 1.

Discussion

For prothrombotic diseases, it has been possible to prospectively gather information on risks associated with inherited traits because "gold standard" tests are available to determine event rates for high-risk situations. It has been more challenging to collect similar data for bleeding disorders, as gold standards for defining excessive bleeding are lacking, some disorders are hard to diagnose, and situations like QPD (whereby large numbers of affected and unaffected blood relatives or appropriately matched controls are available for evaluation) are rare. In many bleeding disorders, the magnitude of risk for experiencing different symptoms and complications has never been formally evaluated. The large family with QPD provided a unique opportunity to evaluate bleeding risks for descendants of a common ancestor with unusual, profibrinolytic, platelet abnormalities and to collect more information on responses of QPD bleeding to fibrinolytic inhibitor therapy. Inheritance of QPD was associated with very high odds ratios (> 20) for experiencing bruises that spread lower or were the size of an orange or larger, joint bleeds, bleeding more than 24 hours after dental extractions or deep cuts, excessive bleeding with surgery(ies) requiring other therapies or blood transfusions, and having received

Table 3. Cardiac disease, strokes, and thrombotic problems in the family with QPD

Experienced	% (proportion) responding with the problem		OR	95% CI
	U	A		
Heart problems, heart attacks and/or angina	5 (5/104)	0 (0/23)	α	0.1- α
Thrombosis: DVT, PE, or both	2 (2/104)	4 (1/23)	0.4	0.03-13
Stroke	1 (1/104)	4 (1/23)	0.2	0.01-8

OR and 95% CI compare unaffected (U) to affected (A) family members. DVT indicates deep vein thrombosis; and PE, pulmonary embolism.

or been recommended fibrinolytic inhibitor therapy for bleeding. The risks of experiencing other bleeding problems with QPD (eg, nosebleeds, bruising disproportionate to trauma, hematuria, or prolonged menses) were significant but not as high (OR, 3.7-14), because these symptoms were also reported by unaffected family members. Unexplained hematuria and joint bleeds were quite prevalent (43%-50%) among the family members with QPD. Although many with QPD had experienced abundant bruising or bleeding (57%) or had modified their lifestyle to reduce bleeding (60%), in many others excessive bleeding had mainly occurred with exposures to significant hemostatic challenges. These data have clarified the nature and spectrum of bleeding problems that can be directly attributed to QPD.

Not surprisingly, overall bleeding histories were different for affected and unaffected QPD family members, but diagnostic testing proved important for clarifying the status of some individuals, particularly the very young without prior exposures to significant hemostatic challenges. Overall bleeding scores for individuals with QPD did not show a relationship with reduced platelet counts or higher platelet stores of u-PA. However, the individuals with QPD and wound healing problems had significantly lower platelet counts, and those with hematuria had significantly higher platelet stores of u-PA. As other symptoms with OR more than 1 showed no relationship to platelet count or platelet u-PA levels, it is possible that inheritance of other hemorrhagic or prothrombotic traits influences the phenotype and variability in QPD bleeding symptoms.

A number of studies have observed bleeding problems among otherwise healthy control subjects,^{2,3,5-9,19,20} and within the family with QPD we similarly identified a few unaffected individuals who had symptoms (and higher bleeding scores), suggestive of a mild bleeding problem. As some "unaffected" individuals reported excessive bruising, in combination with other symptoms such as mild to moderate epistaxis and abnormal bleeding with hemostatic challenges, it is possible that they could have a different kind of bleeding problem, such as von Willebrand disease or a platelet function defect, not evaluated in our study. Nonetheless, these observations raise questions about the types of bleeding symptoms that should be considered abnormal or trigger laboratory investigations.

Few studies have used standardized history assessment tools to evaluate bleeding problems,² and data are lacking on the sensitivity and specificity of different symptoms in distinguishing coagulation defects from platelet disorders. Individuals with QPD have bleeding symptoms with features of coagulation defects (eg, delayed bleeding after dental extractions, joint bleeds) and platelet problems (eg, bruising). It is possible that the combination of a family history of QPD (or QPD-like bleeding problems) and a personal history of delayed bleeding after dental extractions or deep cuts, excessive bleeding with hemostatic challenges that responds to fibrinolytic inhibitor therapy, with or without joint bleeds and unexplained hematuria, could help discriminate QPD from other bleeding disorders. Although genetic traits are undoubtedly important determinants of bleeding in the family with QPD, exposures to environmental or situational factors (eg, surgery, trauma, dental extractions) had profound effects on some manifestations of QPD, whereas other manifestations (eg, hematuria, joint bleeds) were reported without identified antecedent challenges. Although our study questionnaire was not designed to estimate risk reductions according to administered therapy(ies), the comments made by individuals with QPD exposed to hemostatic challenge(s) with or without fibrinolytic inhibitor therapy indicated that excessive or serious bleeding occurred only when this therapy was not given.

Moreover, some serious bleeds occurred with relatively minor procedures, such as circumcision. These data illustrate that for QPD bleeding risks of hemostatic challenges can be significantly reduced by fibrinolytic inhibitors. Although information on the optimal treatment for QPD is limited to data derived from these patients and experiences in managing their bleeding, we feel that therapy with fibrinolytic inhibitors is warranted for treating their joint bleeds and for treating and preventing bleeding with hemostatic challenges, including surgical procedures such as a circumcision. Hematuria in individuals with QPD has always resolved without drug therapy.

It is curious that mice with QPD-like increased u-PA in platelets suffer from problems with fetal losses and fatal postpartum hemorrhages,¹⁸ whereas none of the 5 female participants with QPD who had been pregnant reported unsuccessful pregnancies or life-threatening postpartum bleeding, and only 2 of the 5 had required blood transfusions during childbirth. Although some women with QPD had received prophylactic therapy with fibrinolytic inhibitors during childbirth, some had uncomplicated childbirth without this therapy, and none had experienced bleeding that required fibrinolytic inhibitor therapy during pregnancy. Affected and unaffected mothers and fathers in the family with QPD had similar numbers of offspring. Moreover, in earlier generations of this family (which included individuals who did not participate in our study), a few women who transmitted QPD to their offspring gave birth to many children without experiencing serious bleeding problems at a time when medical care was less sophisticated and fibrinolytic inhibitors were not yet recognized to help QPD bleeding. Currently, we do not believe that there is a need for fibrinolytic inhibitor therapy during uncomplicated childbirth in QPD. Better outcomes with pregnancy in QPD, compared with the animal model, could reflect differences in the amounts of u-PA stored and released by platelets, coupled with higher platelet counts in mice,²¹ or species differences in other factors that influence reproductive health or fibrinolysis, such as plasminogen activator inhibitor-1 (PAI-1).

High prevalences of thrombotic and atherosclerotic diseases in modern society have fostered interest in developing new anticoagulants for preventing and treating arterial and venous thrombosis. Genetically modified mice with increased platelet u-PA show some protection against arterial and venous thrombosis, at the cost of significant bleeding.¹⁸ Our study was not adequately powered to determine whether inheriting QPD similarly protects against arterial and venous thrombosis, because event rates were low among the study participants whose mean age was only 34 years. The individual with QPD who suffered a pulmonary embolism (while receiving appropriate fibrinolytic inhibitor treatment) illustrates that inheriting QPD does not absolutely preclude such events from happening and suggests that prophylaxis against thrombosis might be warranted if fibrinolytic inhibitors must be administered at times of increased thrombotic risk. We could not quantify risks of less common, potentially fatal bleeding problems, such as spontaneous intracranial hemorrhages, and only one affected participant had suffered a hemorrhagic stroke. However, 3 family members with QPD, who are now dead, are also known to have suffered hemorrhagic strokes (from intracranial bleeds),¹² which are less common than thrombotic strokes in the general population.²² More information on the risks and benefits of inheriting QPD may be revealed in longitudinal studies of the family.

Our observation that a detailed bleeding questionnaire helps discriminate affected from unaffected individuals within the QPD family suggests it will be possible to develop standardized history assessment

tools to evaluate bleeding problems. Some questions in our abbreviated questionnaire proved very useful for QPD; however, data are needed on their value for other bleeding problems. Serious bleeding following hemostatic challenges (unless fibrinolytic inhibitors were administered) was the most striking problem experienced by individuals with QPD, and many had morbidity from recurrent joint bleeds or hematuria. We are currently administering our more detailed bleeding history question-

naire prospectively to newly referred patients with bleeding problems and retrospectively in patients with a variety of known and unknown bleeding problems. At this time, it is difficult to provide many individuals who have inherited bleeding defects with precise estimates of their bleeding risks, but advances in bleeding assessment tools provide hope that eventually this information will become possible.

References

- Hayward CPM. Inherited platelet disorders. *Curr Opin Hematol*. 2003;10:362-368.
- Šrámek A, Eikenboom JCJ, Briët E, Vandenbroeke JP, Rosendaal FR. Usefulness of patient interview in bleeding disorders. *Arch Int Med*. 1995;155:1409-1415.
- Sadler JE, Blinder M. Diagnosis and classification of von Willebrand disease. In: Coleman RW, Hirsh J, Marder VJ, Clowes AW, George JN, eds. *Hemostasis and Thrombosis: Basic Principles and Clinical Practice*. Philadelphia: Lippincott Williams and Wilkins; 2001:825-837.
- Hayward CPM. Extending knowledge on inherited platelet disorders associated with thrombocytopenia. *Thromb Haemost*. 2003;90:770-771.
- Lee CA. Women and inherited bleeding disorders: menstrual losses. *Semin Hematol*. 1999;3(suppl 4):21-27.
- Kouides PA, Phatak PD, Burkart P, et al. Gynaecological and obstetrical morbidity in women with type 1 von Willebrand disease: results of a patient survey. *Hemophilia*. 2000;6:643-648.
- Kadir RA, Economides DL, Sabin CA, et al. Assessment of menstrual blood loss and gynaecological problems in patients with inherited bleeding disorders. *Haemophilia*. 1999;5:40-48.
- Kadir RA, Economides DL, Sabin CA, et al. Frequency of inherited bleeding disorders in women with menorrhagia. *Lancet*. 1998;351:485-489.
- Nosek-Cenkowska B, Cheang MS, Pizzi NJ, et al. Bleeding/bruising symptomatology in children with and without bleeding disorder. *Thromb Haemost*. 1991;65:237-241.
- Sadler JE. Von Willebrand disease type 1: a diagnosis in search of a disease. *Blood*. 2003;101:2089-2093.
- Tracy PB, Giles AR, Mann KG, Eide LL, Hoogendorn H, Rivard GE. Factor V (Quebec): a bleeding diathesis associated with a qualitative platelet factor V deficiency. *J Clin Invest*. 1984;74:1221-1228.
- Hayward CPM, Rivard GE, Kane WH, et al. An autosomal dominant, qualitative platelet disorder associated with multimerin deficiency, abnormalities in platelet factor V, thrombospondin, von Willebrand factor, and fibrinogen and an epinephrine aggregation defect. *Blood*. 1996;87:4967-4978.
- Hayward CPM, Cramer EM, Kane WH, et al. Studies of a second family with the Quebec platelet disorder: evidence that the degradation of the alpha-granule membrane and its soluble contents are not secondary to a defect in targeting proteins to alpha-granules. *Blood*. 1997;89:1243-1253.
- Kahr WHA, Zheng S, Sheth PM, et al. Platelets from patients with the Quebec platelet disorder contain and secrete abnormal amounts of urokinase-type plasminogen activator. *Blood*. 2001;98:257-265.
- Sheth PM, Kahr WHA, Haq MA, et al. Intracellular activation of the fibrinolytic cascade in the Quebec Platelet Disorder. *Thromb Haemost*. 2003;90:293-298.
- Hayward CPM, Welch B, Bouchard M, Zheng S, Rivard GE. Fibrinogen degradation products in patients with the Quebec platelet disorder. *Br J Haematol*. 1997;97:497-503.
- Janeway CM, Rivard GE, Tracy PB, Mann KG. Factor V Quebec revisited. *Blood*. 1996;87:3571-3578.
- Kufrin D, Eslin DE, Bdeir K, et al. Antithrombotic thrombocytes: ectopic expression of urokinase-type plasminogen activator in platelets. *Blood*. 2003;102:926-933.
- Miller CH, Graham JB, Goldin LR, Elston RC. Genetics of classic von Willebrand's disease. I. Phenotypic variation within families. *Blood*. 1979;54:117-136.
- Miller CH, Graham JB, Goldin LR, Elston RC. Genetics of classic von Willebrand's disease. II. Optimal assignment of the heterozygous genotype (diagnosis) by discriminant analysis. *Blood*. 1979;54:137-145.
- Kaushansky K, Fox N, Lin NL, Liles CW. Lineage-specific growth factors can compensate for stem and progenitor cell deficiencies at the postprogenitor cell level: an analysis of double TPO- and G-CSF receptor-deficient mice. *Blood* 2002;99:3573-3578.
- Dennis MS. Outcome after brain hemorrhage. *Cerebrovasc Dis*. 2003;16(suppl 1):9-13.